

DESCRIPTION

The combined safety cage and crane fork has been designed especially for the Building and construction industry. The CFA/C is designed to lift palletised loads of bricks, blocks and bags of cement and plaster etc. The load is locked in to the crane fork cage for safe high level handling of materials on building sites. The crane fork can be used without the cage to lift palletised loads into the safety cage at low levels. Crane forks can be supplied with automatic self-weight balance mechanisms or with a manual balance mechanism (for additional information on the crane forks see CFA and CFM data sheets).

DIAGRAM

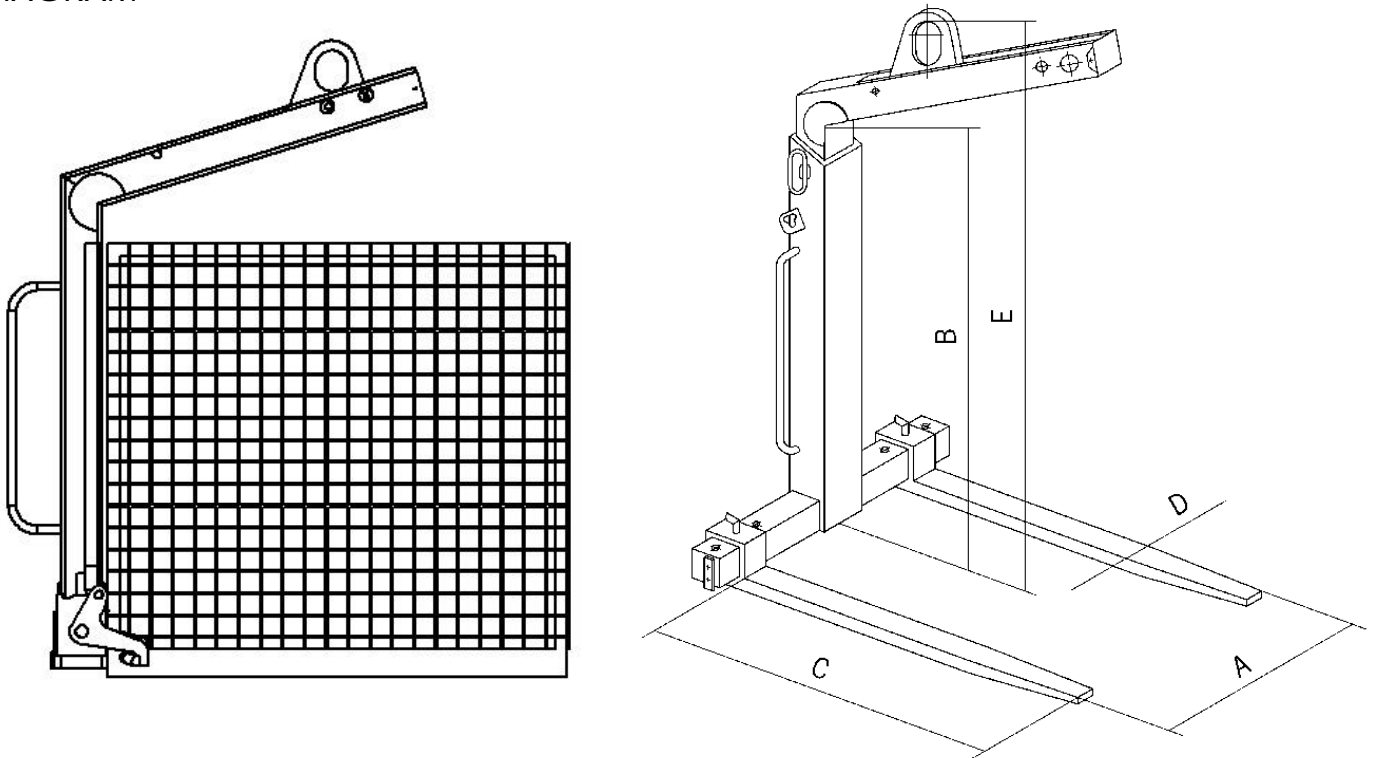

SAFETY CAGE

The combined safety cage and crane fork can be designed to lift several sizes of palletised loads. The cage can be designed and manufactured to suit many sizes and capacities for varying requirements.

CRANE FORK TABLE

MODEL	WLL Tons	Weight kg	A	B	C	D	E
CFA 1.0	1.0	140	350-500	1100-1600	1000	100 X 30	1420-1920
CFA 1.5	1.5	165	350-500	1300-2000	1000	100 X 40	1650-2350
CFA 2.0	2.0	220	400-500	1300-2000	1000	120 X 40	1655-2355
CFA 3.0	3.0	280	450-500	1300-2000	1000	120 X 50	1720-2400
CFA 5.0	5.0	380	500-1000	1300-2000	1000	150 X 60	1710-2410

APPLICATIONS

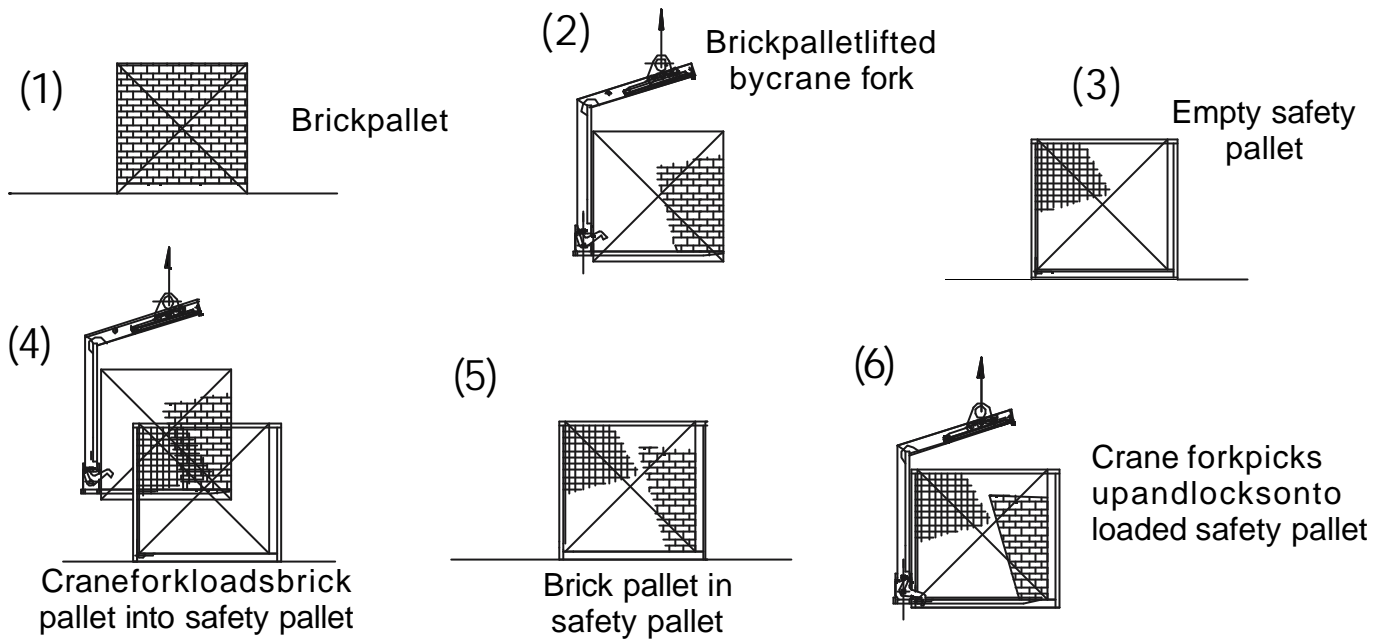

RESTRICTIONS

The hooking trolley will not move to the centre of gravity of the load unless the weight of the load is a minimum of 20% of the rated WLL of the crane fork. Always read operating instructions before use.

OPTIONS

Options in this range include varying sizes of cage depending on application, manually and automatically adjustable lifting rings.

The manual-lifting ring has several settings for lifting the fork in the loaded or unloaded position. The balancing position engages when the shackle is manually hooked into the appropriate notch.

The shackle (lifting ring) is movable and runs on a track depending on the load. The automatic balancing system engages by a pressurised gas spring once the forks are loaded. The load will always be in the centre of gravity of the forks.

CFM
Manually adjustable
lifting ring

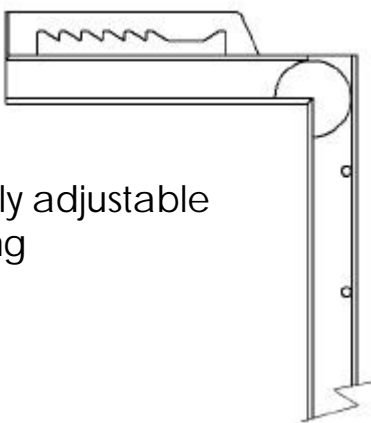

CFA

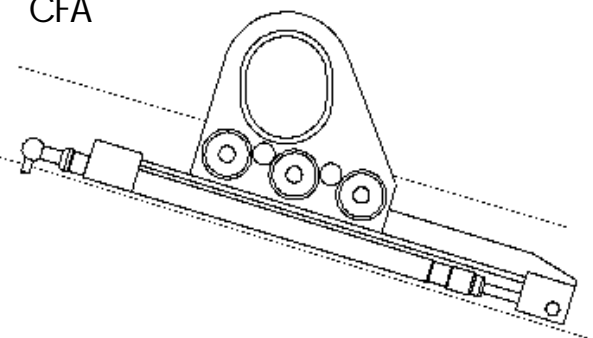

Automatically adjustable lifting ring