

## DESCRIPTION

The C FA crane forks are supplied as standard with both tines centers and height adjustable to suit a variety of pelletized loads

The hooking trolley is connected to a gas spring that automatically balances the crane fork when it is unloaded.

## DIAGRAM

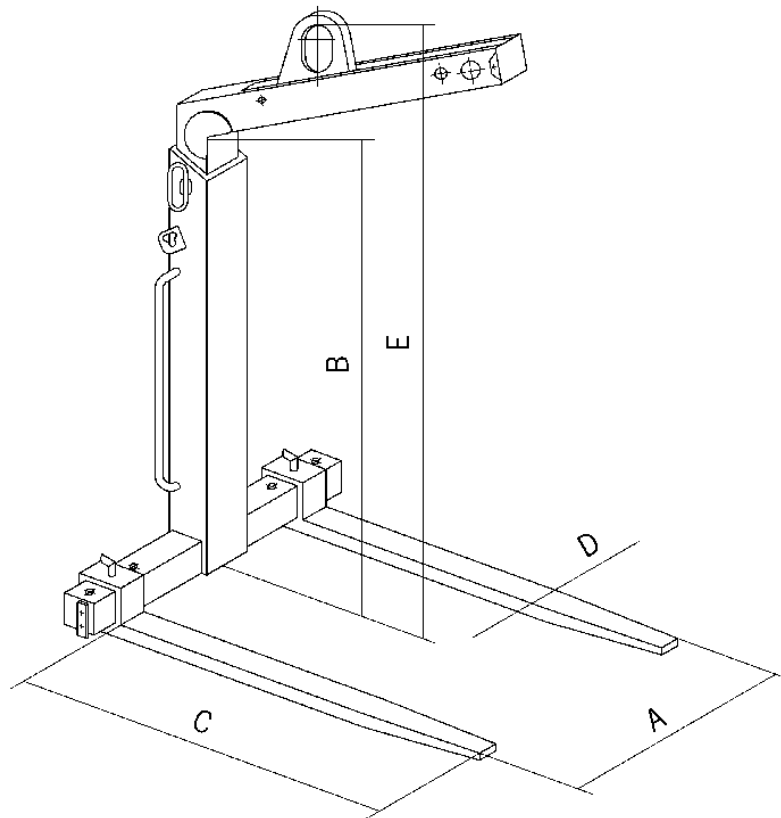

## TABLE

MODEL	WLL Tons	Weight kg	A	B	C	D	E
CFA 1.0	1.0	140	350-500	1100-1600	1000	100X30	1420-1920
CFA 1.5	1.5	165	350-500	1300-2000	1000	100X40	1650-2350
CFA 2.0	2.0	220	400-500	1300-2000	1000	120X40	1655-2355
CFA 3.0	3.0	280	450-500	1300-2000	1000	120X50	1720-2400
CFA5.0	5.0	380	500-1000	1300-2000	1000	150X60	1710-2410