

DESCRIPTION

The CFM crane fork are supplied as standard with adjustable height and tine centres to suit a variety of palletised loads. When transporting rings or coils the tines can be pushed together. The balancing system engages when the shackle is manually hooked into the appropriate notch.

DIAGRAM

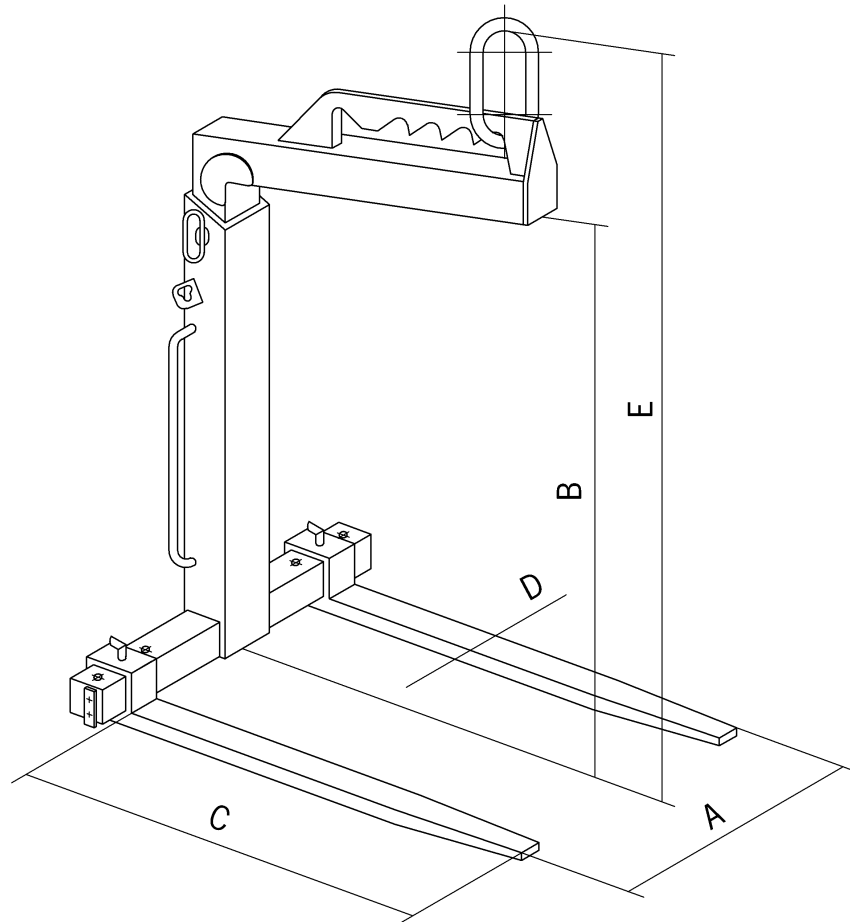

TABLE

MODEL	WLL Tons	Weight kg	A	B	C	D	E
CFM 1	1.0	130	350-900	1100-1600	1000	100 X 30	1390-1890
CFM 1.5	1.5	150	350-900	1300-2000	1000	100 X 40	1600-2300
CFM 2.0	2.0	200	400-900	1300-2000	1000	120 X 40	1640-2340
CFM 3.0	3.0	250	450-900	1300-2000	1000	120 X 50	1670-2370
CFM 5.0	5.0	370	500-1000	1300-2000	1000	150 X 60	1700-2400