

DESCRIPTION

The MR is designed to facilitate the fast and safe bulk handling of rail sections. The clamps are used in pairs and retain the rail sections rigidly in the flange toe to flange toe position, thus eliminating the necessity of levering rails into position when stowing or fastening down on wagons. Rails are locked onto the clamp by swivelling feet that locate under the rail-head, and the top clamp body that rotates in a cam action pressing a hard rubber lined horizontal curved beam onto the top of the rail-head. The rubber lined contact beam prevents marking or damage to the rail-head.

DIAGRAM

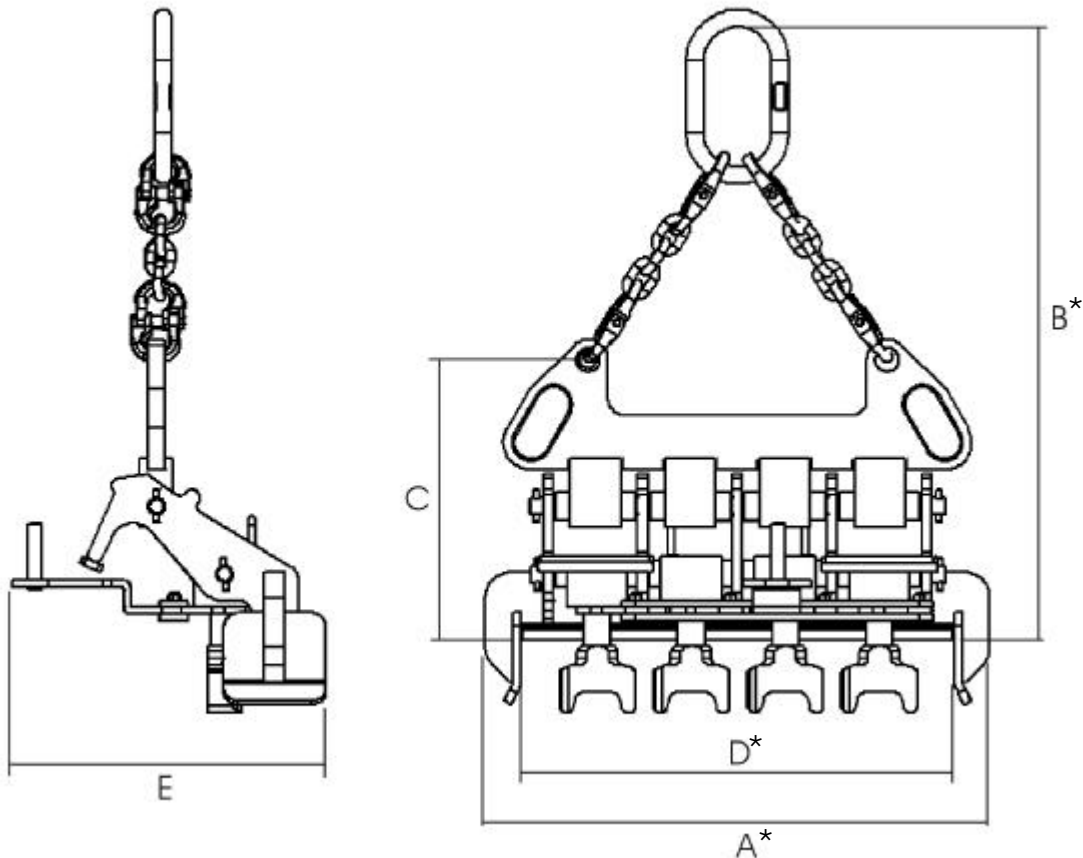

* = MAY VARY DEPENDING ON NUMBER OF RAILS

TABLE

MODEL	No. of Rails	WLL Tonnes	Weight kg	A	B	C	D	E
MR 3	3	5	84	480	890	415	380	475
MR 4	4	5	108	630	710	415	530	475
MR 5	5	5	132	780	790	415	680	475
MR 6	6	6	156	930	850	415	830	475
MR 7	7	7	180	*	*	415	*	475
MR 8	8	8	204	*	*	415	*	475
MR 10	10	10	252	*	*	415	1380	475
MR 12	12	12	300	1830	1900	415	1730	475