

DESCRIPTION

The MRC is designed to facilitate the fast and safe bulk handling of rail sections. The clamps are used in pairs and retain the rail (or conductor/transfer section) in the base flange to base flange position, thus eliminating the necessity of levering rails into position when stowing or fastening down on wagons. The clamp is of modular design in two parts. The top part of the clamp is a scissor mechanism that is connected to the lower comb section, which is interchangeable. The MRC can be fitted with an automatic open/close device if required.

DIAGRAM

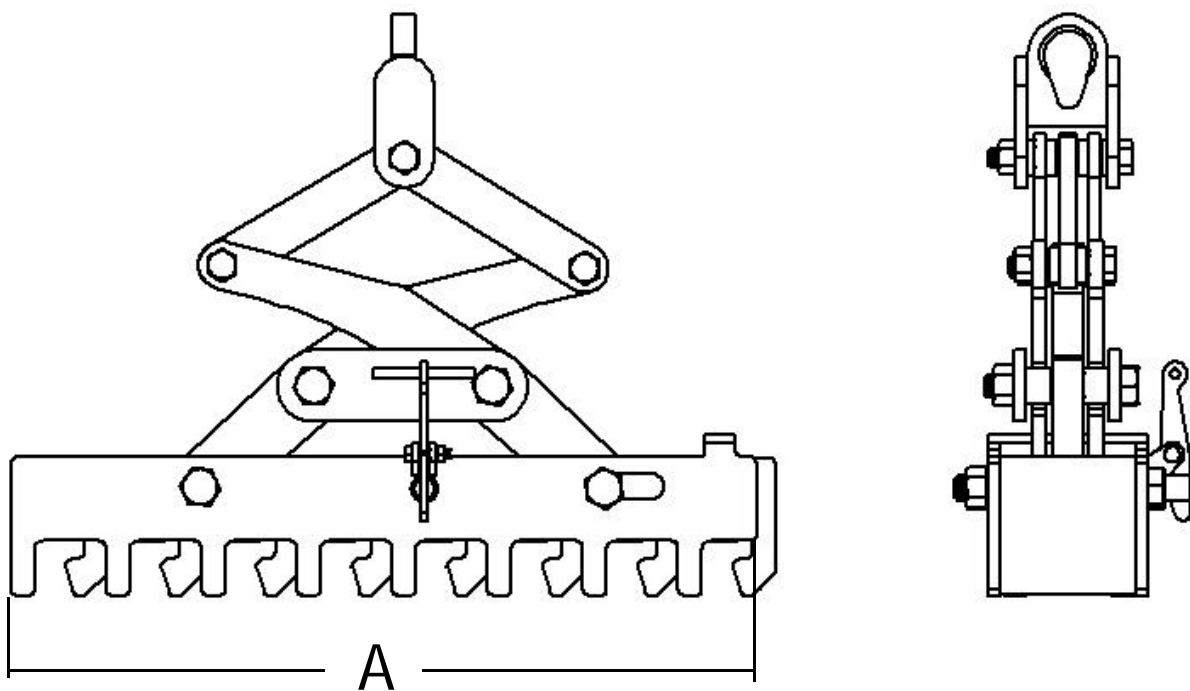

TABLE

MODEL	No. of Rails	WLL Tonnes	Weight kg	A mm
MRC 3	3	5	185	Min – 940 Overall size Depends on Type and Number of Rails
MRC 4	4	5	200	
MRC 5	5	5	230	
MRC 6	6	6	265	
MRC 7	7	7	295	
MRC 8	8	8	330	
MRC 10	10	10	405	
MRC 12	12	12	480	